

REVISION

ISS	ZONE	DESCRIPTION

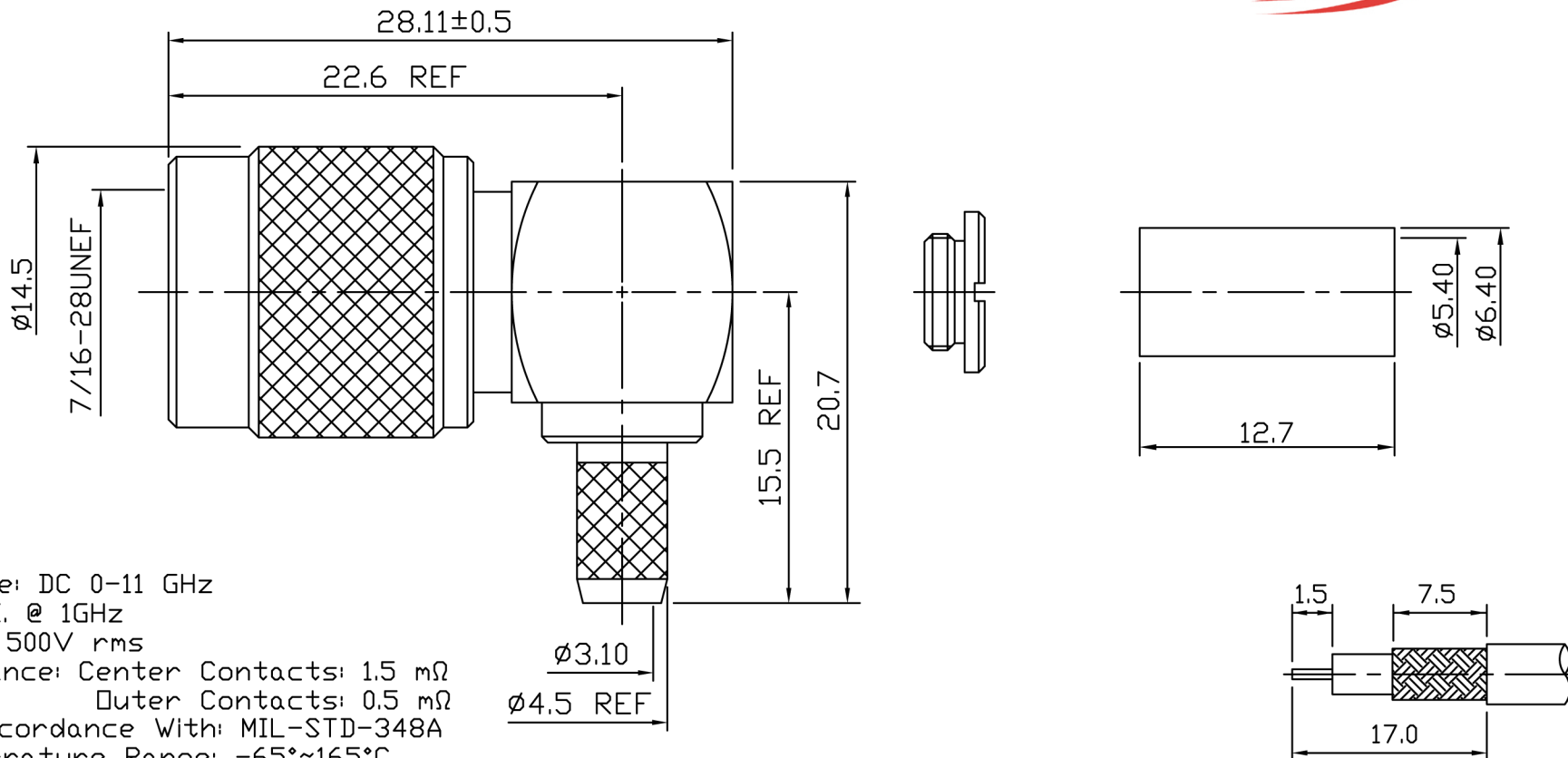

- NOTE:
- 1.Impedance: 50Ω
 - 2.Frequency Range: DC 0-11 GHz
 - 3.V.S.W.R.: 1.35 MAX. @ 1GHz
 - 4.Voltage Rating: 500V rms
 - 5.Contact Resistance: Center Contacts: 1.5 mΩ
Outer Contacts: 0.5 mΩ
 - 6.Interface in Accordance With: MIL-STD-348A
 - 7.Operating Temperature Range: -65°~165°C
 - 8.RoHS Compliance.

NO.	DESCRIPTION	MATERIAL	FINISH	Q'TY	DRAWN NO.
10	FERRULE	BRASS	NICKEL	1	M-0046
9	NUT	BRASS	NICKEL	1	D-0016
8	BARREL	BRASS	NICKEL	1	E-0173
7	BODY B	BRASS	NICKEL	1	B-0812
6	CENTER CONTACT	BRASS	GOLD	1	C-0656
5	BODY A	BRASS	NICKEL	1	B-0811
4	WASHER	BRASS	NONE	1	G-0023
3	GASKET	RUBBER	NONE	1	R-0007
2	INSULATOR	TEFLON	NONE	1	T-0471
1	SHELL	BRASS	NICKEL	1	A-0010

TOLERANCES			
DIMENSIONS ARE IN MILLIMETER			
UNLESS OTHERWISE SPECIFIED			
.X		±0.2	
.XX		±0.1	
.XXX		±0.05	
ANGLES		±5°	

TITLE
Right Angle RPTNC Plug for TWS-195 Cable
PART NO.
CON-02RA-195
DRAWN NO.
FILE PATH:

TerraWave Solutions	
APPROVED	DATE
CHECKED	DATE
DRAWN	DATE