

REVISION

ISS	ZONE	DESCRIPTION

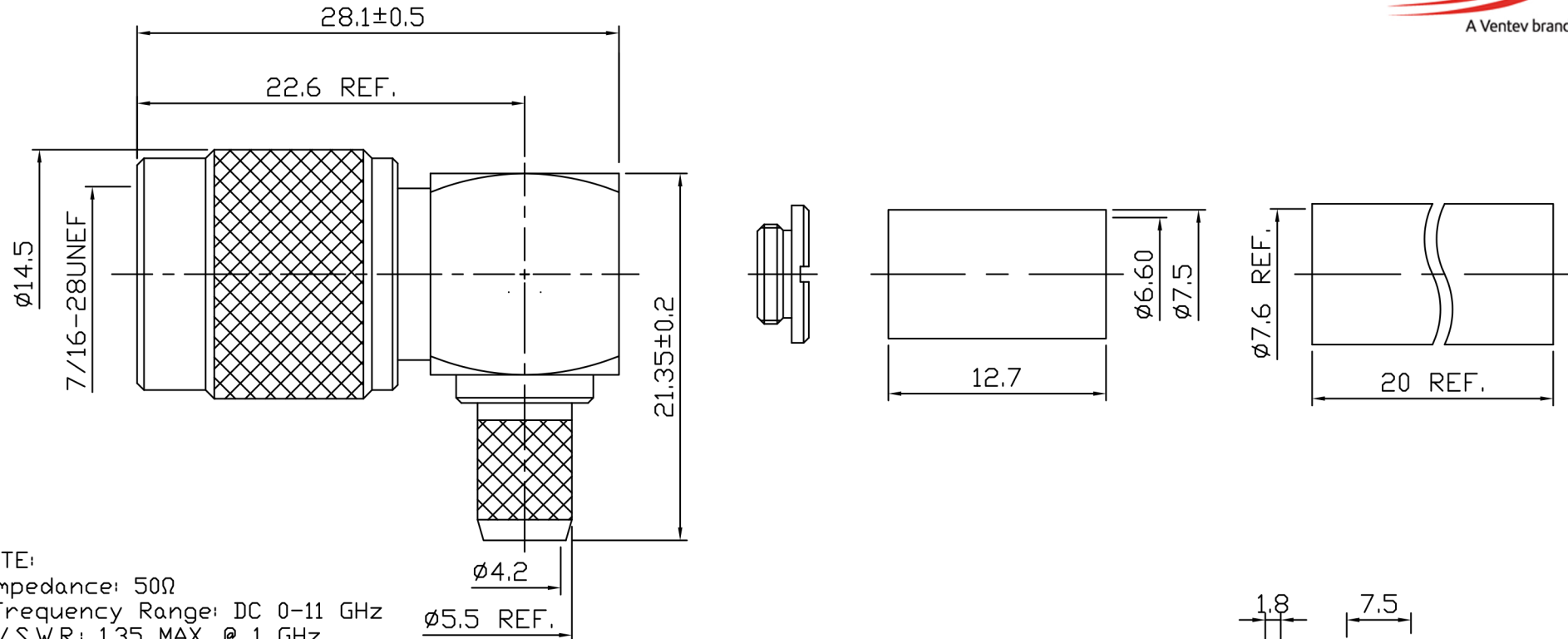

- NOTE:
- 1.Impedance: 50Ω
 - 2.Frequency Range: DC 0-11 GHz
 - 3.V.S.W.R.: 1.35 MAX. @ 1 GHz
 - 4.Voltage Rating: 500V rms
 - 5.Contact Resistance: Center Contacts: 1.5 mΩ
Outer Contacts: 0.5 mΩ
 - 6.Operating Temperature Range: -65°~165°C
 - 7.ROHS Compliance.

STRIPPING DIMENSION

NO.	DESCRIPTION	MATERIAL	FINISH	Q'TY	DRAWN NO.
10	HEAT TUBING	PE	BLACK	1	H-0006
9	FERRULE	BRASS	NICKEL	1	M-0067
8	NUT	BRASS	NICKEL	1	D-0016
7	BODY B	BRASS	NICKEL	1	B-0918
6	CENTER CONTACT	BRASS	GOLD	1	C-0760
5	BODY A	BRASS	NICKEL	1	B-0917
4	WASHER	BRASS	NONE	1	G-0023
3	GASKET	SILICONE	NONE	1	R-0007
2	INSULATOR	TEFLON	NONE	1	T-0594
1	SHELL	BRASS	NICKEL	1	A-0010

TOLERANCES			
DIMENSIONS ARE IN MILLIMETER			
UNLESS OTHERWISE SPECIFIED			
.X	±0.2		
.XX	±0.1		
.XXX	±0.05		
ANGLES	±5°		

TITLE		APPROVED		DATE	
Right Angle RPTNC Plug for TWS-240 Cable					
PART NO.		CHECKED		DATE	
CON-02RA-240					
DRAWN NO.		DRAWN		DATE	
FILE PATH:					