

FOR CUSTOMER

REMARK: RoHS COMPLIANT

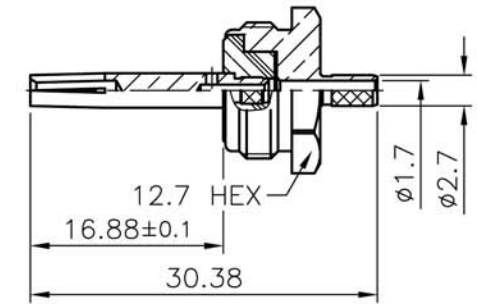

- NOTES: FINISH (PLATING THICKNESS IN MICRO-INCHES)
1. BRASS PER QQ-B-626
 2. NICKEL PL 70 MIN THICK OVER COPPER STRIKE
 3. GOLD PL 3 MIN OVER NICKEL PL 70 MIN THICK OVER COPPER STRIKE
 4. TEFLON MIL-P-19468
 5. PHOSPHOR BRONZE PER QQ-B-750
 6. BRASS JIS H 3100, C 2680
 7. BRASS JIS H 3250, C 2700

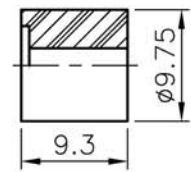
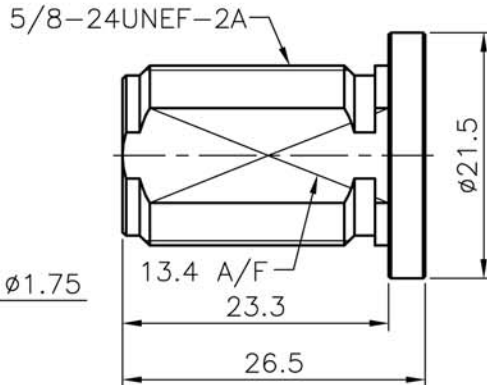
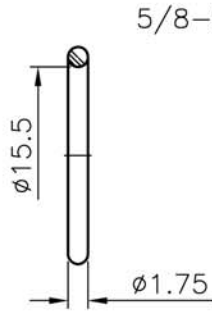
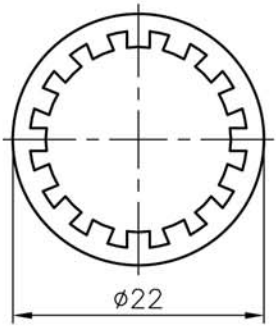
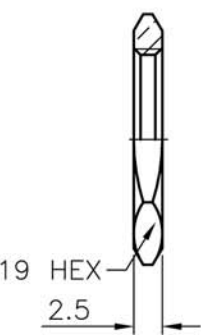
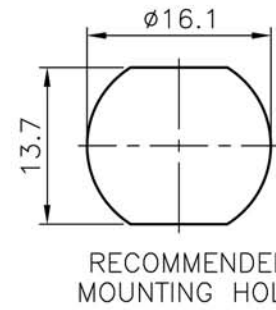
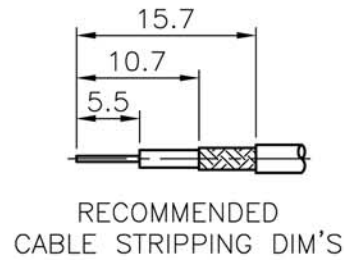
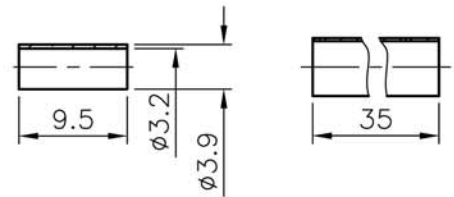

1. CRIMPED FERRULE
HEX CRIMP SIZE .128" (3.25mm)
2. CONTACT PIN TO SOLDER
3. MAX. PANEL THICKNESS=8.5mm

NO.	DESCRIPTION	MATERIAL	FINISH	Q'TY	DRAWING NO.
	HEAT SHRINK TUBE		BLACK		
	NUT	NOTE 1	NOTE 2		
	WASHER	NOTE 6	NOTE 2		
	GASKET	RUBBER	BLACK		
	FERRULE	NOTE 7	NOTE 2		
	BRAID HOLDER	NOTE 1	NOTE 2		
	INSULATOR	NOTE 4	WHITE		
	CONTACT PIN	NOTE 5	NOTE 3		
	INSULATOR	NOTE 4	WHITE		
	BODY	NOTE 1	NOTE 2		

DIMENSIONS ARE IN MILLIMETERS UNLESS OTHERWISE SPECIFIED TOLERANCES				PART NO. CON-08-100		TerraWave Solutions	
0.5~6	= ±0.2	APPROVED	DATE	TITLE N-Style Bulkhead Jack for TWS-100 Cable			
>6~30	= ±0.4	CHECKED	DATE				
>30~120	= ±0.6	DRAWN	DATE				
>120~315	= ±1			DRAWING NO.			
>315~1000	= ±1.6			FILE NO.			
ANGLES	= ±5°	SCALE	1.5/1	ISSUE	A1		