

REVISIONS		DESCRIPTION \ DATE
ISS	SYMBOL	

REMARK: RoHS COMPLIANT

FOR CUSTOMER

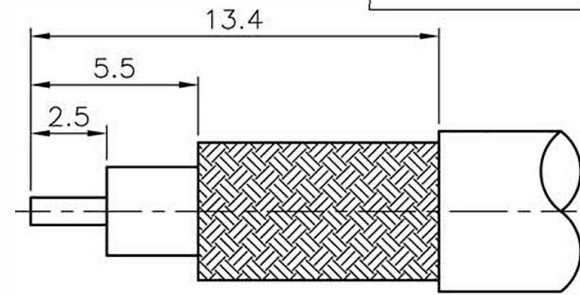
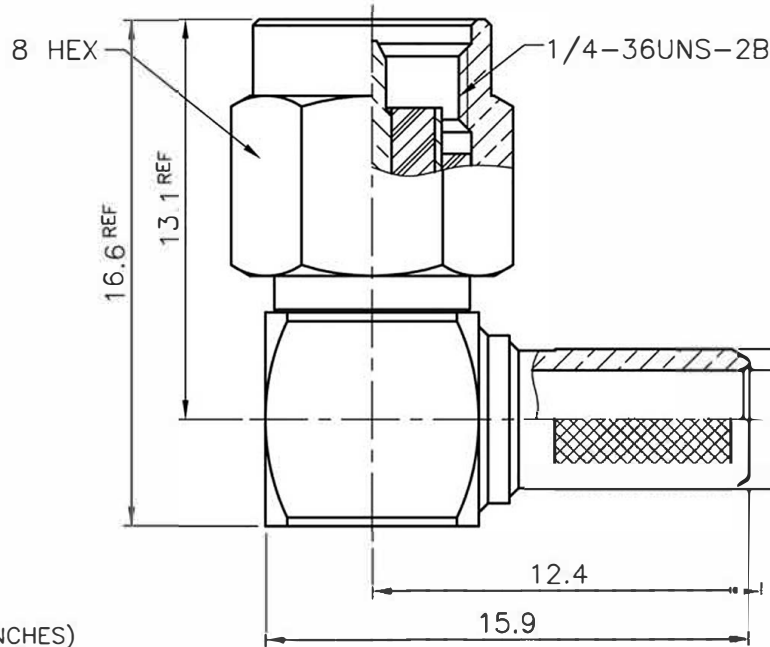
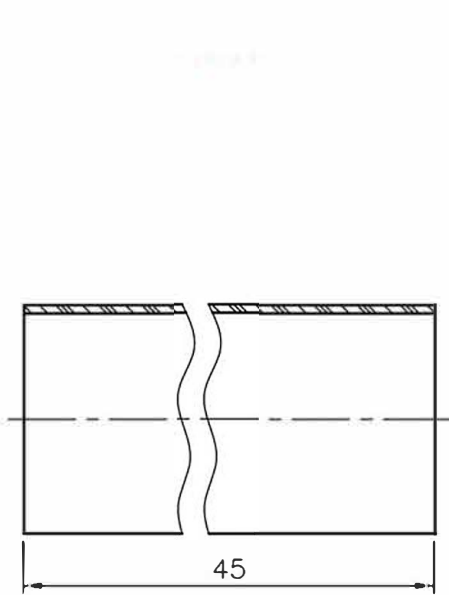

RECOMMENDED CABLE STRIPPING DIM'S

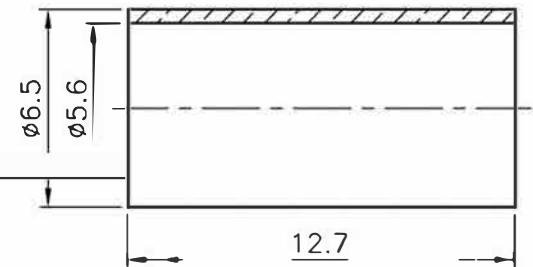

NOTES: FINISH (PLATING THICKNESS IN MICRO-INCHES)

1. BRASS PER QQ-B-626
2. NICKEL PL 70 MIN THICK OVER COPPER STRIKE
3. GOLD PL 30 MIN OVER NICKEL PL 70 MIN THICK OVER COPPER STRIKE
4. TEFLON MIL-P-19468
5. BRASS JIS H 3250, C 2700
6. BERYLLIUM COPPER PER QQ-C-530

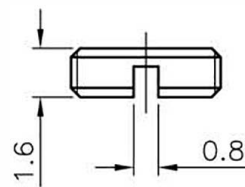

1. CRIMPED FERRULE
HEX CRIMP SIZE .213" (5.41mm)

2. CONTACT PIN TO SOLDER

HEAT SHRINK TUBE		BLACK			
FERRULE	NOTE 5	NOTE 2			
COVER	NOTE 1	NOTE 2			
SHELL	NOTE 1	NOTE 2			
GASKET	SILICONE	RED			
C RING	NOTE 6	NONE			
CUBE BODY	NOTE 1	NOTE 2			
CONTACT PIN	NOTE 1	NOTE 3			
INSULATOR	NOTE 4	WHITE			
BODY	NOTE 1	NOTE 2			
NO.	DESCRIPTION	MATERIAL	FINISH	Q'TY	DRAWING NO.

DIMENSIONS ARE IN MILLIMETERS			
UNLESS OTHERWISE SPECIFIED TOLERANCES			
0.5~6	=	±0.2	
>6~30	=	±0.4	
>30~120	=	±0.6	
>120~315	=	±1	
>315~1000	=	±1.6	
ANGLES = ±5°			
SCALE	4/1	ISSUE	A1

PART NO.	
CON-18-195-RA	
APPROVED	DATE
CHECKED	DATE
DRAWN	DATE

TITLE	
Right Angle SMA Plug for TWS-195 Cable	
DRAWING NO.	
FILE NO.	