

REVISIONS		DESCRIPTION \ DATE
ISS	SYMBOL	
A1		

REMARK: RoHS COMPLIANT FOR CUSTOMER

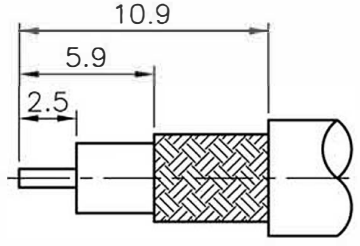

RECOMMENDED CABLE STRIPPING DIM'S

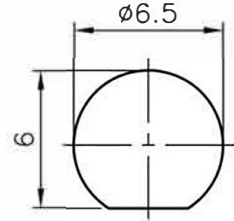

RECOMMENDED MOUNTING HOLE

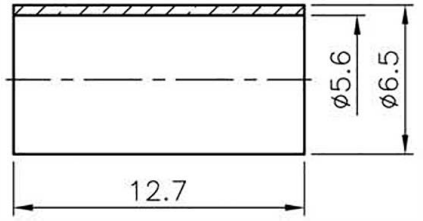
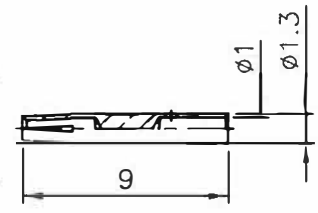
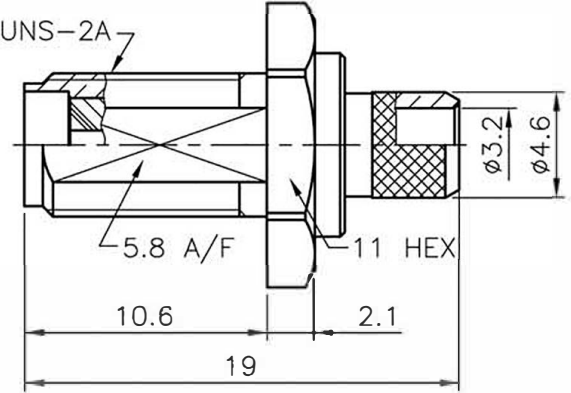
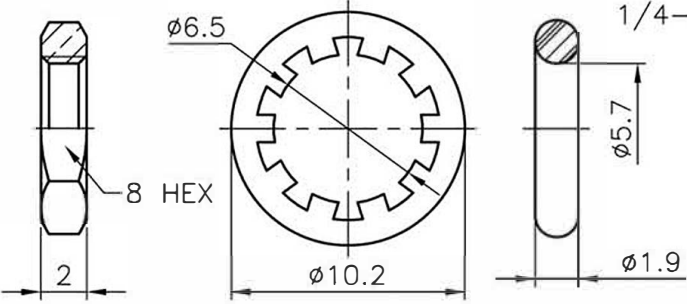

- NOTES: FINISH (PLATING THICKNESS IN MICRO-INCHES)
1. BRASS PER QQ-B-626
 2. GOLD PL 5 MIN OVER NICKEL PL 70 MIN THICK OVER COPPER STRIKE
 3. TEFLON MIL-P-19468
 4. GOLD PL 30 MIN OVER NICKEL PL 70 MIN THICK OVER COPPER STRIKE
 5. BRASS JIS H 3250, C 2700
 6. BERYLLIUM COPPER PER QQ-C-530

1. CRIMPED FERRULE
HEX CRIMP SIZE .213" (5.41mm)
2. CONTACT PIN TO SOLDER
3. MAX. PANEL THICKNESS=1.6mm

NO.	DESCRIPTION	MATERIAL	FINISH	Q'TY	DRAWING NO.	SCALE	3/1	ISSUE	A1
	NUT		NOTE 1	NOTE 2		DIMENSIONS ARE IN MILLIMETERS			
	WASHER		SS41	NOTE 2		UNLESS OTHERWISE SPECIFIED TOLERANCES			
	GASKET		RUBBER	BLACK		0.5~6 = ±0.2			
	FERRULE		NOTE 5	NOTE 2		>6~30 = ±0.4			
	CONTACT PIN		NOTE 6	NOTE 4		>30~120 = ±0.6			
	INSULATOR		NOTE 3	WHITE		>120~315 = ±1			
	BODY		NOTE 1	NOTE 2		>315~1000 = ±1.6			
						ANGLES = ±5°			

PART NO.		CON-23-195	
APPROVED	DATE		
CHECKED	DATE		
DRAWN	DATE		



TITLE
SMA Bulkhead Jack for TWS-195 Cable

DRAWING NO.

FILE NO.