

REVISIONS

ISS	SYMBOL	DESCRIPTION\DATE

REMARK: RoHS COMPLIANT  
(符合 RoHS)



FOR CUSTOMER

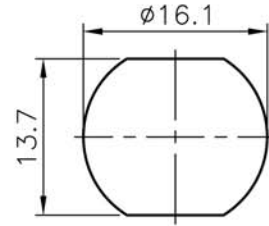

RECOMMENDED MOUNTING HOLE

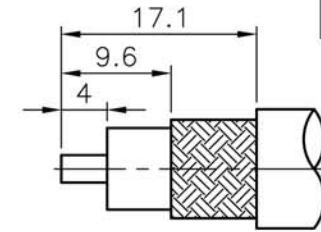

RECOMMENDED CABLE STRIPPING DIM'S

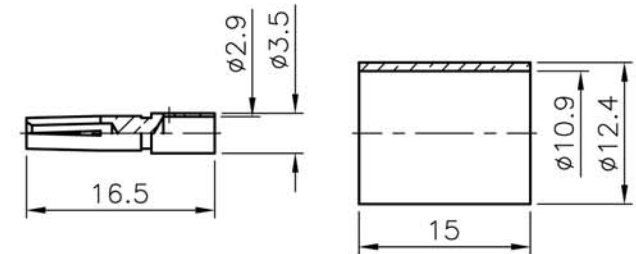
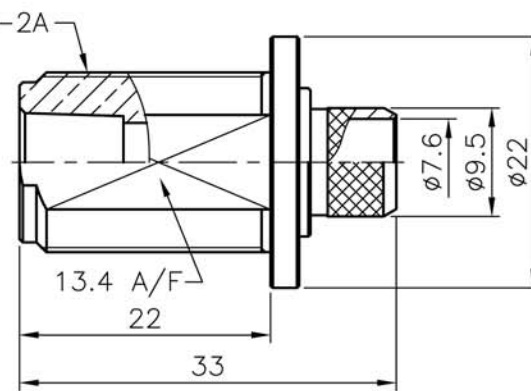
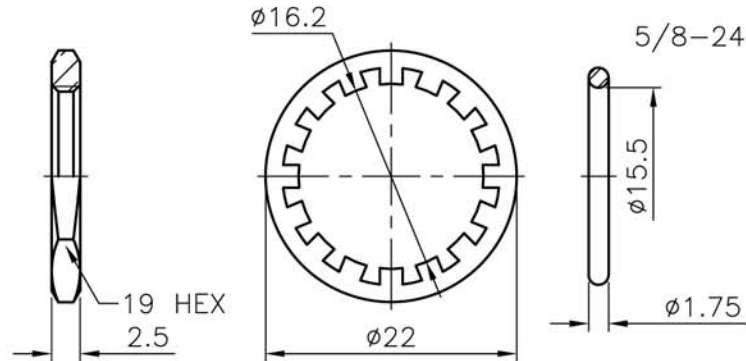

NOTES: FINISH (PLATING THICKNESS IN MICRO-INCHES)

- BRASS PER QQ-B-626
- NICKEL PL 70 MIN THICK OVER COPPER STRIKE
- GOLD PL 3 MIN OVER NICKEL PL 70 MIN THICK OVER COPPER STRIKE
- TEFLON MIL-P-19468
- PHOSPHOR BRONZE PER QQ-B-750
- BRASS JIS H 3100, C 2680
- BRASS JIS H 3250, C 2700

- CRIMPED FERRULE  
HEX CRIMP SIZE .429" (10.9mm)
- CRIMPED CONTACT PIN  
HEX CRIMP SIZE .118" (3mm) OR SOLDER
- MAX. PANEL THICKNESS=6.5mm

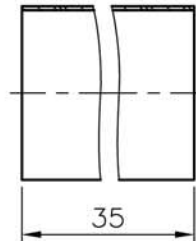

NO.	DESCRIPTION	MATERIAL	FINISH	Q'TY	DRAWING NO.
	HEAT SHRINK TUBE	PE	BLACK		
	NUT	NOTE 1	NOTE 2		
	WASHER	NOTE 6	NOTE 2		
	GASKET	RUBBER	BLACK		
	FERRULE	NOTE 7	NOTE 2		
	CONTACT PIN	NOTE 5	NOTE 3		
	BRAID HOLDER	NOTE 1	NOTE 2		
	INSULATOR	NOTE 4	WHITE		
	BODY	NOTE 1	NOTE 2		

DIMENSIONS ARE IN MILLIMETERS			
UNLESS OTHERWISE SPECIFIED TOLERANCES			
0.5~6	=	±0.2	
>6~30	=	±0.4	
>30~120	=	±0.6	
>120~315	=	±1	
>315~1000	=	±1.6	
ANGLES	=	±5°	

PART NO.		CON-08-400	
APPROVED	DATE		
CHECKED	DATE		
DRAWN	DATE		

TerraWave Solutions	
TITLE	N-Style Bulkhead Jack for TWS-400 Cable
DRAWING NO.	
FILE NO.	