

REVISIONS		DESCRIPTION\DATE
ISS	SYMBOL	

REMARK: RoHS COMPLIANT FOR CUSTOMER

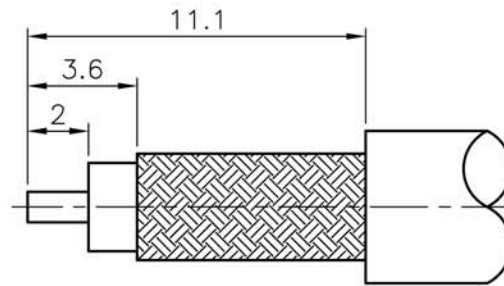

RECOMMENDED
CABLE STRIPPING DIM'S

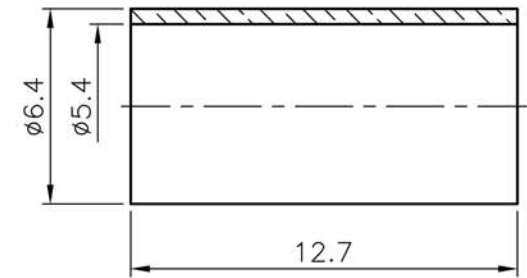
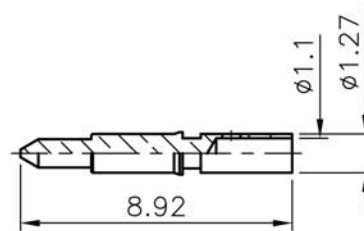
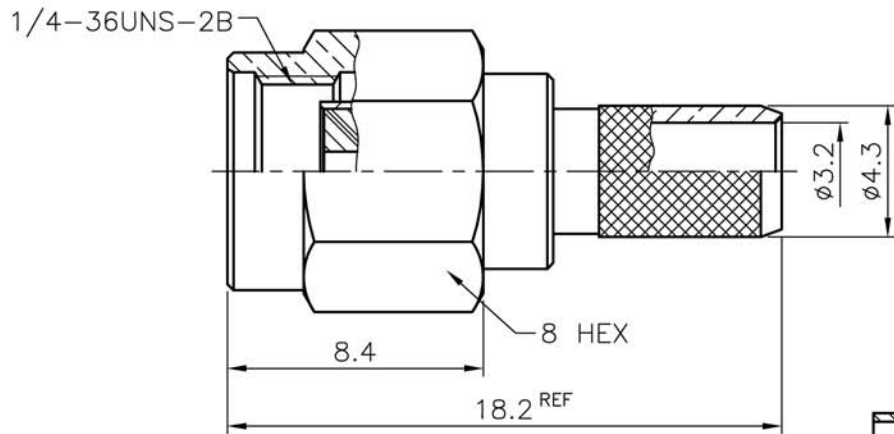

NOTES: FINISH (PLATING THICKNESS IN MICRO-INCHES)

1. BRASS PER QQ-B-626
2. NICKEL PL 70 MIN THICK OVER COPPER STRIKE
3. GOLD PL 30 MIN OVER NICKEL PL 70 MIN THICK OVER COPPER STRIKE
4. TEFLON MIL-P-19468
5. BERYLLIUM COPPER PER QQ-C-530
6. BRASS JIS H 3250, C 2700

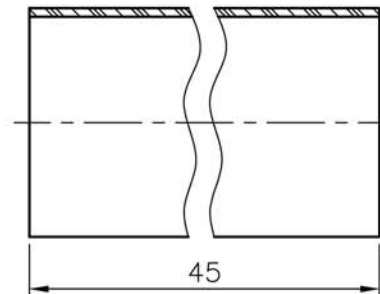

1. CRIMPED FERRULE
HEX CRIMP SIZE .213" (5.41mm)
2. CONTACT PIN TO SOLDER

NO.	DESCRIPTION	MATERIAL	FINISH	Q'TY	DRAWING NO.	SCALE	4/1	ISSUE	A1	PART NO.	DATE	TITLE	
	HEAT SHRINK TUBE		BLACK							CON-18-195		SMA Plug for TWS-195 Cable	
	FERRULE	NOTE 6	NOTE 2								APPROVED		DATE
	CONTACT PIN	NOTE 1	NOTE 3								CHECKED		DATE
	SHELL	NOTE 1	NOTE 2								DRAWN		DATE
	C RING	NOTE 5	NONE										
	GASKET	SILICONE	RED										
	INSULATOR	NOTE 4	WHITE									DRAWING NO.	
	BODY	NOTE 1	NOTE 2									FILE NO.	

DIMENSIONS ARE IN MILLIMETERS
UNLESS OTHERWISE SPECIFIED TOLERANCES

0.5~6 = ±0.2
>6~30 = ±0.4
>30~120 = ±0.6
>120~315 = ±1
>315~1000 = ±1.6
ANGLES = ±5°

TerraWave Solutions