

REVISIONS		DESCRIPTION\DATE
ISS	SYMBOL	

REMARK: RoHS COMPLIANT

FOR CUSTOMER

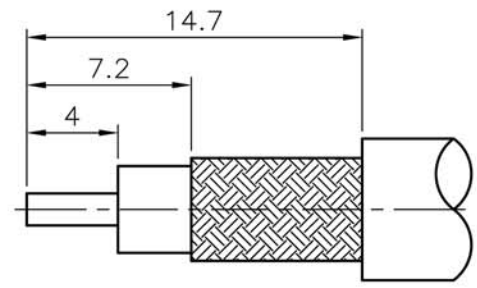

RECOMMENDED CABLE STRIPPING DIM'S

7/16-28UNEF-2A

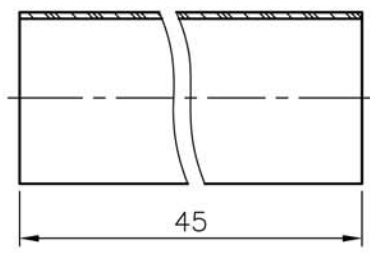
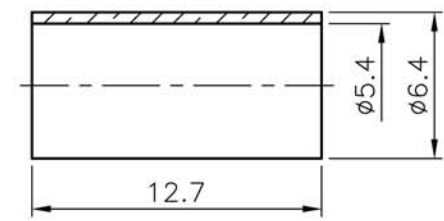
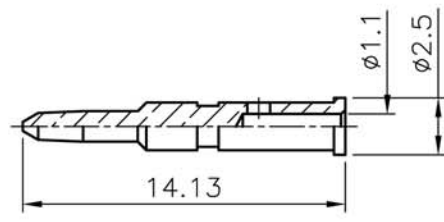
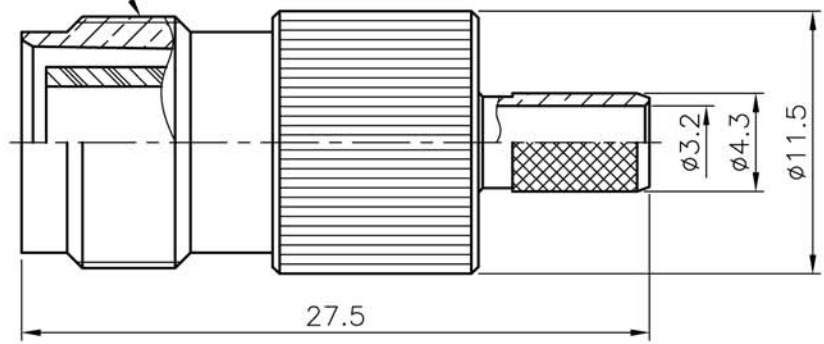

- NOTES: FINISH (PLATING THICKNESS IN MICRO-INCHES)
1. BRASS PER QQ-B-626
 2. NICKEL PL 70 MIN THICK OVER COPPER STRIKE
 3. TEFLON MIL-P-19468
 4. GOLD PL 3 MIN OVER NICKEL PL 70 MIN THICK OVER COPPER STRIKE
 5. BRASS JIS H 3250, C 2700

1. CRIMPED FERRULE
HEX CRIMP SIZE .213" (5.41mm)
2. CRIMPED CONTACT PIN
HEX CRIMP SIZE .068" (1.72mm)

					DIMENSIONS ARE IN MILLIMETERS				PART NO.		TerraWave Solutions	
					UNLESS OTHERWISE SPECIFIED TOLERANCES				CON-01-195			
HEAT SHRINK TUBE					BLACK				APPROVED	DATE	TITLE RPTNC Jack for TWS-195 Cable	
FERRULE					NOTE 5 NOTE 2				CHECKED	DATE		
CONTACT PIN					NOTE 1 NOTE 4				DRAWN	DATE	DRAWING NO.	
LOCK RING					NOTE 1 NOTE 2				0.5~6 = ±0.2 >6~30 = ±0.4 >30~120 = ±0.6 >120~315 = ±1 >315~1000 = ±1.6 ANGLES = ±5°			
INSULATOR					NOTE 3 WHITE							
BODY					NOTE 1 NOTE 2				FILE NO.			
NO.	DESCRIPTION	MATERIAL	FINISH	Q'TY	DRAWING NO.	SCALE	3/1	ISSUE	A1			