

BTRM 300

Battery Test Remote Monitor

20 Amp Load Capacity- Ideal for Solar Applications

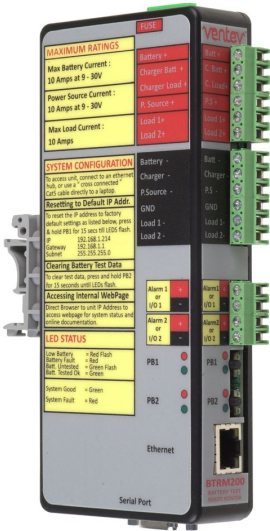

Remote sites powered only by Solar Power Systems where no AC is available depend on reliable batteries. However, batteries have an operational lifespan that can be reduced by environmental factors. Ventev's Battery Test Remote Monitor (BTRM) performs automatic battery load tests and sends exception reports via SNMP, text or email using Ethernet or DNP3 communication protocols. The BTRM continuously assesses the actual battery voltage independent of the charger voltage (float voltage) which is the most reliable method for battery testing. *The Ventev BTRM300 is covered by the company's one-year TerraNet warranty program.*

For more information or to purchase, contact Ventev: 800.851.4965 or sales@ventev.com.

SPECIFICATIONS

Sku:

281170

Product Number:

BTRM-300

Dimensions:

6.25" x 2.8" x 1.2"

Weight:

5.0 oz (142 g)

APPLICATIONS

Ideal for Remote UPS and Solar Power Systems including Oil and Gas or Utility SCADA systems for wireless remote monitoring, Smart Grid, AMI/AMR, security and surveillance.

- The BTRM alarm triggers when batteries fail to meet minimum capacity requirements or have low battery voltage.
- The BTRM issues the appropriate message to the Network Operations Center and/or activates one of the unit's alarm contacts

FEATURES AND BENEFITS

- The BTRM provides reliable testing using the system's own load to evaluate battery health in real-time
- Ensures cost-savings by allowing you to replace batteries near end-of-life but before they fail, and consolidating truck rolls for battery replacement
- Provides peace of mind that if widespread power fails, all systems will operate for the back-up time
- The BTRM is intended to be installed on a private network to maintain security
- Supports the latest in Ethernet communications including SNMP and DNP3
- A two-channel RTU using dry contacts that can be configured for additional I/O
- Each device is IP addressable and is remotely configurable with a web-based GUI
- Units include a user selectable Low Voltage Disconnect On/Off
- Two dry contacts are available for basic TRU functionality. Example configurations include:
 - Door alarm
 - AC power off or on (for UPS enclosures only)
 - DC power off or on

BTRM 300

Battery Test Remote Monitor

As batteries age their capacity slowly deteriorates until they need replacement. Batteries can also develop an internal fault suddenly that limits their capacity. When batteries are used 24/7 this can result in premature, or in some cases immediate, system shutdown. Although a battery's state of charge can be inferred by monitoring the battery terminal voltage while in standby mode, this voltage will not give an indication of actual capacity. A battery that is marginal may not be detected until it is called upon to perform during inclement weather, at which point it is too late to prevent a system failure. For a battery connected to a solar controller that maintains a voltage, neither condition can be checked. In these cases, the BTRM is designed to evaluate battery capacity transparently to system operation and provide a network-based notification should the battery fail, or its capacity drops below a specified level. This also allows batteries that exceed their nominal lifetime to remain in service, provided they meet capacity requirements.

BTRM300	
OPERATING VOLTAGE	9 to 32 VDC
Battery Max Current	20 A Continuous
Charger Max Current	20 A Continuous
Load Max Current	20 A Continuous
Battery & Charger Voltage Measurement	0 to 32V ± 1%
Current Measurement	0 to 20 Amps ± 1%
Environmental Operating Temperature	-20° C to 60° C
Humidity	5% to 95% Non-Condensing
Mounting	DIN Rail

Web-based GUI

- IP Addressable
- Name each device for location or coordinates
- Configure testing parameters

BTRM 300 Battery Test Remote Monitor

BTRM Solar Wiring Diagram

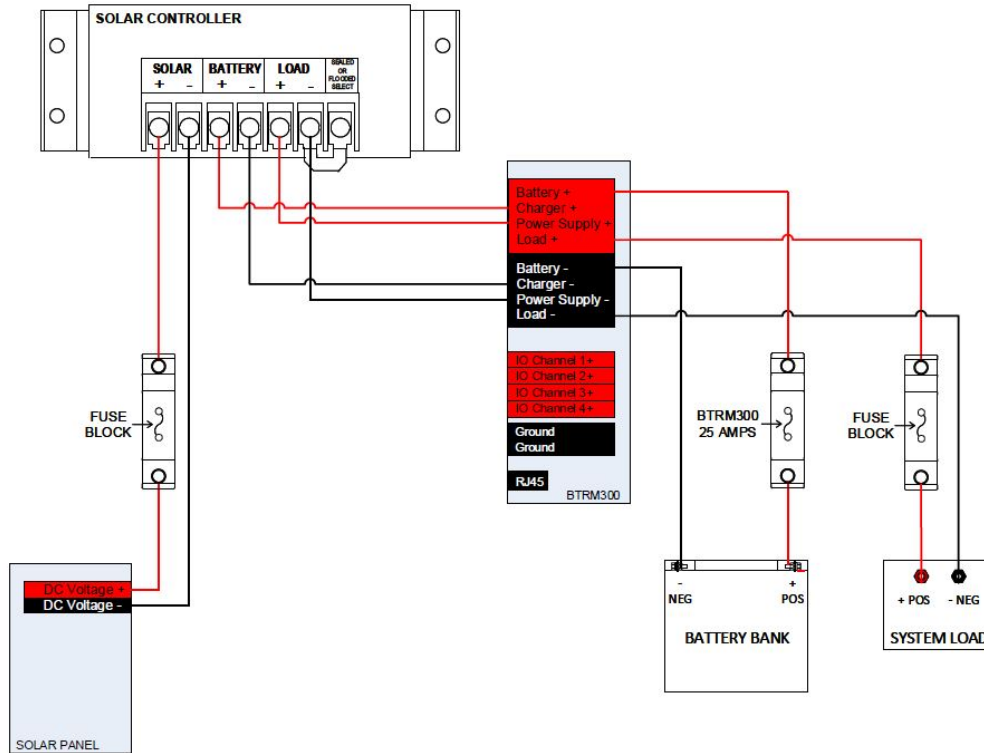

BTRM Solar Alarm Wiring Diagram

