

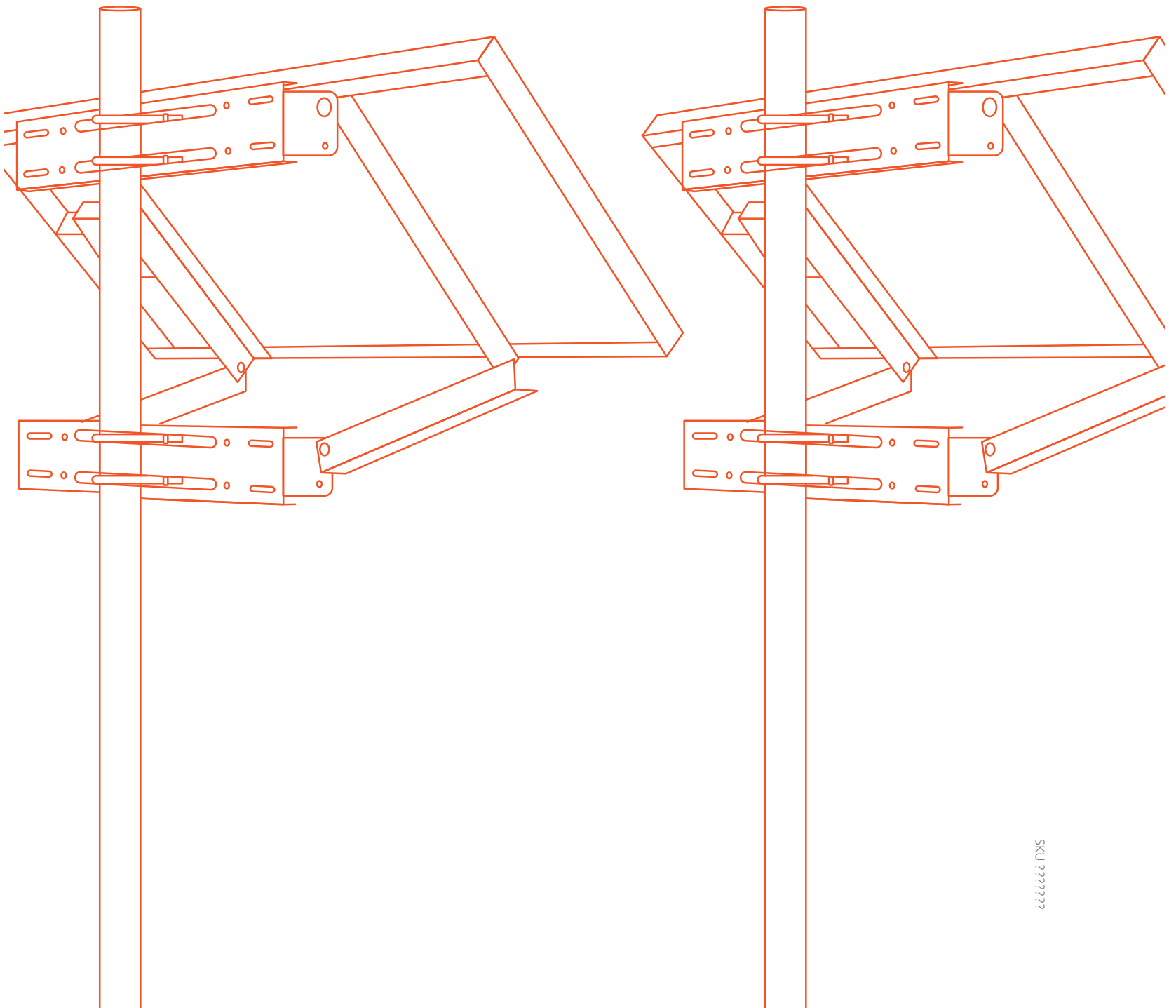

Installation, Operation, & Maintenance Manual

Solar Power System



SKU 222222

Contents

- 1: Introduction 3**
 - 1.1 Special Considerations 3**
 - 1.2 Definition of Warning Statements 4**
 - 1.3 Notice 4**
 - Copyright 4*
 - Trademarks 4*
 - Federal Communications Commission (FCC) Notice 4*
 - CE Compliance 4*
 - 1.4 Technical Support 4**
- 2: Theory of Operation 5**
- 3: System Installation 6**
 - 3.1 Overview 6**
 - 3.2 Recommended Installation Tools 6**
 - 3.3 Site Location 6**
 - 3.4 Mechanical Assembly 7**
 - 3.4.1 Mounting Pole Installation 7*
 - 3.4.2 Solar Module Support Structure Assembly 7*
 - 3.4.3 System Enclosure Mounting 8*
 - 3.5 System Wiring 8**
 - 3.5.1 Grounding 8*
 - 3.5.2 Battery Installation and Wiring 8*
 - 3.5.3 Array Wiring 8*
 - 3.5.4 Load Wiring 8*
 - 3.6 System Checkout and Commissioning 9**
 - System Installation Checklist And Start-Up Data Table 9*
- 4: Recommended Maintenance 10**
 - 4.1 Solar Array 10**
 - 4.2 Charge Controller 10**
 - 4.3 Battery Bank 10**
 - 4.4 System Wiring 10**
- 5: System Troubleshooting 11**

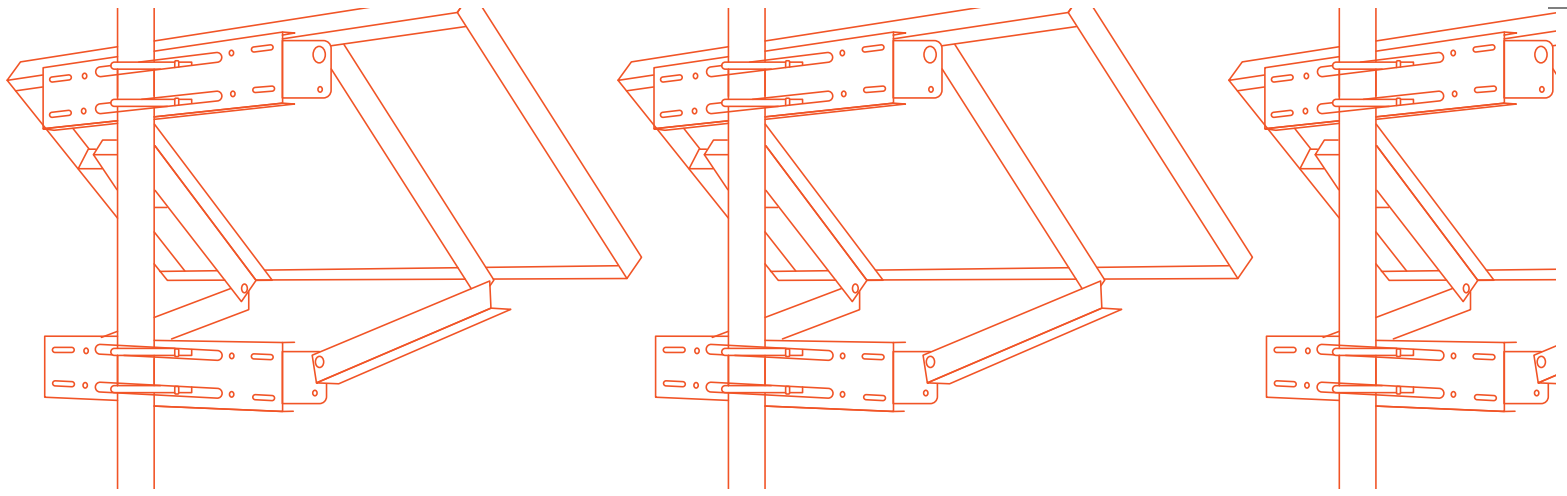

1: Introduction

Ventev, a division of TESSCO Technologies Inc., designs and manufactures industry-leading Wi-Fi and wireless infrastructure products, to ensure reliable network performance and simplify the installation of Wi-Fi, IoT, LTE, DAS, and two-way networks. After you choose the radio, choose Ventev to connect, protect, and enable your wireless radio network. For more information, visit ventevinfra.com.

1.1 Special Considerations

Special care must be taken to ensure an unobscured view of the sun by the solar module. Shadowing of the solar module by trees, equipment poles, structural elements and even power lines will greatly diminish the output of the solar system. Modules must also be at the correct tilt angle and must face towards the equator for maximum efficiency. Solar modules installed near or at the equator are efficient at a zero-tilt angle. It is best to situate the tilt angle at five to ten degrees to facilitate a washing action when it rains. This is especially important at remote installations where maintenances are typically at a minimum.

Battery life and efficiency is directly influenced by two main issues. They are temperature and maximum depth of charge. It is important to design the solar charge system using a conservative load and a reasonable number of days of no-sun (days of autonomy). Doing so, will ensure a long life of the charging system. Discharging the battery lower than the manufacturers recommended total depth of discharge (TDD), is very important to avoid. Temperature of the surrounding environment will also affect the life and efficiency of the battery. Battery life is directly influenced by very cold and hot environments. If the yearly primary temperature is hot, it is best to locate the controller housing in a shaded area, for example below the solar module. By doing so, the enclosure and the battery within will be shielded from direct sun light. Conversely, the solar charging enclosure should be installed in the sun, in predominately cold locations. Both extreme temperatures will affect battery efficiency and life.

1.2 Definition of Warning Statements

This manual contains important instructions for use during installation and maintenance of the Solar Power System. To reduce the risk of electrical shock, and to ensure the safe installation and operation of the Solar Power System, the following safety symbols appear throughout this document to indicate dangerous conditions and important safety instructions.

DANGER	Indicates an imminently hazardous situation which, if not avoided, will result in death or serious injury
WARNING	Indicates an imminently hazardous situation which, if not avoided, will result in death or serious injury
ELECTRICAL HAZARD	Indicates an electrical hazard, which if not avoided, could result in death or serious injury. Use extreme caution and follow instructions carefully.
Note	This indicates information particularly important for optimal system operation. Follow instructions closely.

1.3 Notice

This guide is provided for informational use only. Every effort was made to ensure the accuracy of information in this guide at the time of release. Ventev reserves the right to provide updates to the content not available at the time this guide was released.

Copyright

January 2022, TESSCO Technologies, Inc. All rights reserved. Ventev Innovations is a division of TESSCO Technologies, Inc. Ventev Innovations and its logo are trademarks of TESSCO Technologies, Inc. All other trademarks and registered trademarks are the property of their respective owners. All content included in this guide, including illustrations, diagrams, and instructions were created by Ventev Innovations, a TESSCO Technologies, Inc. company. No part of this guide may be reproduced manually or electronically without written permission from TESSCO Technologies, Inc. All material(s) not solely and exclusively created by Ventev Innovations have been used in strict accordance with all applicable Copyright laws and is protected by the individual creators Copyright.

Trademarks

- Ventev is a trademark or registered trademark of TESSCO Technologies, Inc. in the United States and/or other countries.
- Tessco is a trademark or registered trademark of TESSCO Technologies, Inc. in the United States and/or other countries.

Federal Communications Commission (FCC) Notice

The Solar Power System is designed to meet the limits pursuant to Part 15 of the FCC rules.

CE Compliance

Solar Power Systems are designed to be CE compliant.

1.4 Technical Support

If you are unable to resolve issues after referring to this manual, please contact technical support for additional help:

Ventev Innovations (A division of TESSCO Technologies)
 10999 McCormick Rd, Hunt Valley, MD 21031
 Phone: 1-800-759-9996

2: Theory of Operation

The Solar Power System is the most reliable as it is safer and takes less time to install than other systems saving money and increasing safety. This manual describes safe installation and operation of the power system.

The three key elements of the Solar Power System include:

- Solar Modules
- Batteries
- Solar Charge Controller

This integrated system maximizes energy harvest, increases system reliability, and simplifies design, installation, and management. The photovoltaic array supplies current to the batteries which is regulated by the solar charge controller. The terminal voltage of the batteries is monitored along with limiting the charge current as required.

The photovoltaic array will supply current to charge the battery bank. The controller will monitor the battery terminal voltage and limit the charging current to the battery bank as required. As the battery voltage rises to 14.2VDC (multiply by 2 for 24V system) the controller will limit the current from the solar array to maintain the terminal voltage and prevent the battery from being overcharged. The temperature compensation feature assures the battery is properly charged in cold temperature and not overcharged in warm temperatures (Refer to the controller manual for additional details on charge regulation.)

Additionally, the controller contains a Low Voltage Disconnect (LVD). This feature will disconnect the load if battery voltage falls to a voltage of 11.5VDC (multiply by two for 24V system). This unusual feature could occur in situations where there are continuous days of cloudy weather or any time the system fails to provide power to the load. This feature will prevent the battery from being over-discharged to level that could damage and shorten its life. When the battery has been charged to a voltage of 12.6VDC (Multiply by two for 24V system), the controller will reconnect the battery to the load.

3: System Installation

3.1 Overview

Installing pole mounted solar power systems are easy and convenient. All systems are pre-assembled and tested. All that is required is to erect and fasten the mounting pole, mount the solar module and electrical panel on the mounting pole (pipe stand), install the battery, and make the final wire terminations.

3.2 Recommended Installation Tools

- Phillips Head Screwdrivers
- Straight Blade Screwdriver
- Wire Strippers
- Cable Ties
- Multimeter
- Wire Cutters
- Socket Set (Or Equivalent)
- Compass (To Orientate Solar Modules)

3.3 Site Location

Be sure to mount the solar modules in an area which is free of shade. Shading of the solar modules will significantly reduce, if not kill, the power output. Orientate the solar modules facing the equator. It is recommended to use a GPS or a magnetic compass to find true north and south.

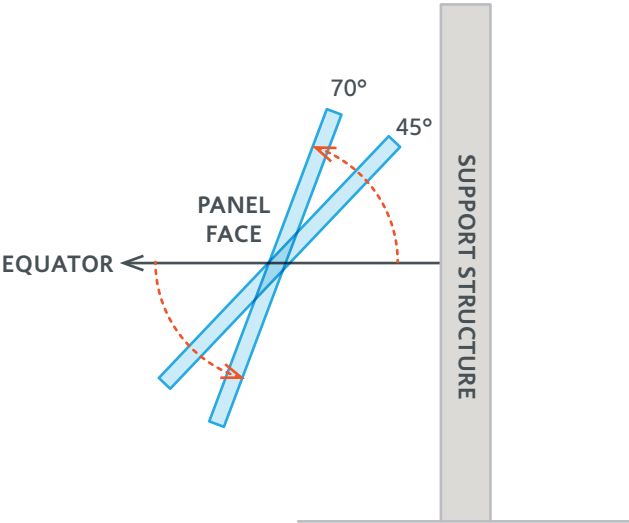

Alabama	45°	Kentucky	60	North Dakota	70
Alaska	80°	Louisiana	45	Ohio	60
Arizona	45°	Maine	65	Oklahoma	50
Arkansas	60°	Maryland	60	Oregon	65
California	45°	Massachusetts	65	Pennsylvania	65
Colorado	55°	Michigan	65	Rhode Island	65
Connecticut	60°	Minnesota	65	South Carolina	55
Delaware	65	Mississippi	45	South Dakota	65
District of Col.	60	Missouri	60	Tennessee	60
Florida	45	Montana	70	Texas	45
Georgia	55	Nebraska	65	Utah	65
Hawaii	40	Nevada	65	Vermont	65
Idaho	65	New Hampshire	65	Virginia	60
Illinois	65	New Jersey	65	Washington	65
Indiana	65	New Mexico	45	West Virginia	60
Iowa	65	New York	65	Wisconsin	65
Kansas	65	North Carolina	60	Wyoming	65

3.4 Mechanical Assembly



Warning

Electrical Shock and Burn Hazard

As you know, solar modules produce electricity when exposed to light. Be sure to use appropriate safety equipment and procedures to prevent shocks and burns. It is recommended to cover the surface of the solar module, to block all light, before performing any operation involving the module.

3.4.1 Mounting Pole Installation

Install all the solar components on to the mounting pole (pipe stand). Ensure the pipe stand has been properly secured and sized in accordance to the project.

3.4.2 Solar Module Support Structure Assembly

The number of solar panels to be installed on the mount will be based on the system requirement and sizing.

Solar Panel
Solar Bracket
Pipe
Channel Foot
Channel
Channel Foot
U-Bolts (Customer provided)
Wind Brace

Adjust channel up and down to get desired array tilt angle.

Hardware sets are provided for mount. Use the 1/4 inch sets of hardware to bolt the solar module(s) to the solar brackets. Hardware bags include 14 sets of 5/16 inch and 4 sets of 1/4 inch. A hardware set consists of the items shown in the bottom left figure.

HARDWARE SET

1 Bolt
1 Nut
2 Washers
1 Lock Washer

Bolt
Washer
Aluminum
Lock Washer
Nut

3.4.3 System Enclosure Mounting

Attach the electrical enclosure to the pipe stand using U-bolts. The electrical enclosure may be orientated in any direction (whichever direction is most desired).

3.5 System Wiring



Warning

Explosion hazard. Do not disconnect while the circuit is live or unless the area is free of the ignitable concentrations.

Before any wiring is done, be sure to turn all breakers to the OFF position.

3.5.1 Grounding

Ground the system electrical panel to the site ground (provided by others) using a bare ground wire.

3.5.2 Battery Installation and Wiring

Cautions:

- **Electrical Hazard:** Use insulated tools when performing any operation on/with the batteries. Failure to do so could result in shock injury.
- **Chemical Hazard:** Batteries contain sulfuric acid which can cause serious injuries if exposed. If contact with sulfuric acid were to occur, immediately and thoroughly wash with water. It is recommended to use safety equipment, such as rubber gloves, rubber apron, and safety goggles.
- **Installation:** Remove the battery from the shipping boxes. Place the battery in the electrical panel on the shelf. Check to make sure all breakers have been turned to the OFF position before continuing. Connect the positive battery cable (red wire) to the battery positive terminal. Next, connect the negative battery cable (black wire) to the battery negative terminal. If applicable, terminate the inter-battery cables as shown in the drawing.

3.5.3 Array Wiring

Terminate the red wire to the positive terminal of the solar module and the other end to the positive solar terminal on the din rail. Terminate the black wire to the negative terminal of the solar module and the other end to the negative solar terminal on the din rail. If applicable, terminate the inter-module cables as shown in the drawing.

3.5.4 Load Wiring



Warning

Explosion hazard. Do not disconnect while the circuit is live or unless the area is free of the ignitable concentrations.

Terminate the load(s) positive wire into the positive terminal on the din rail. Next, terminate the load(s) negative wire into the negative terminal on the din rail.

3.6 System Checkout and Commissioning

Verify all mechanical and electrical connections to ensure the system has been properly installed. Review and perform the following checklist.

1. Verify all hardware and fasteners have been properly fastened.
2. Verify all wires have been properly installed (copper is not exposed; wires are terminated in the correct locations) and are secured tight.
3. Verify the solar module is facing the equator and has the appropriate degree of tilt.
4. Using a multimeter, verify the module's open circuit voltage and open circuit current.
5. Verify the battery voltage is approximately 12.4VDC (multiply by 2 for 24V system) or above.
6. Turn the battery breaker to ON position. Verify the charge regulator's green "Battery Status" is on.
7. Turn the solar and load breakers to ON position. Verify the charge regulator's green "CHARGING STATUS" light is on.

System Installation Checklist And Start-Up Data Table

1. Hardware and fasteners are tight Yes No
2. Wires properly installed and secured Yes No
3. Solar module has the correct orientation Yes No
4. Document the module's open circuit voltage (VOC) and the short circuit current (ISC).

Open circuit voltage _____VDC

Short circuit current _____A

5. Document the battery's initial voltage.

Battery _____VDC

6. Charge regulator status

Battery status LED on Yes No

Battery charging status on Yes No

Installation Is Now Complete

Test performed by: _____ Date: _____

Approved by: _____ Date: _____

4: Recommended Maintenance

4.1 Solar Array

A properly installed solar system requires few solar panel maintenance. However, the following maintenance tips should be kept in mind to keep your solar system in good shape.

- **Solar panel cleaning:** Cleaning of the solar panels is easy, and it ensures that the solar cells are unobstructed and receive the maximum amount of insolation. Clean solar panels are important to maximize the panel's energy output. Cleaning the glass on the panels is a simple procedure that can be carried out as often as required depending on how much dirt is accumulating. To clean panels, you can use a soft cloth or wash rag and biodegradable soap. If you are only dealing with dust you can run a hose pipe with water over the panels.
- **Avoid shading:** Shading is one of the things you already avoid when you do a proper site analysis during pre-installation. Once the panels have been mounted, you need to ensure shades do not come up such as new towering trees, as this will decrease the amount of energy produced by the system. You do not necessarily have to cut down trees, but you can trim them to ensure the panels are not shaded.
- **Regular Inspection:** Inspect all electrical connections for looseness, corrosion, chafing, etc. Inspect the module back surface for damage or punctures. Seal any punctures that are found with a commercial grade RTV sealant. If significant impact damage is observed, replace the affected solar module.

4.2 Charge Controller

- Inspect all electrical connections for looseness or corrosion.
- Look out for LVD warning where the battery discharges to LVD set point at which the load will disconnect, and a solid red battery status LED indication will be displayed.
- Check Charge Controller operation per the manual.

4.3 Battery Bank

- Inspect all electrical connections for looseness or corrosion.
- Check and record battery voltages.

4.4 System Wiring

- Inspect all wiring and connections for tightness, corrosion, insulation integrity, damage, etc. Repair or replace as necessary.

5: System Troubleshooting

The following system can assist you in troubleshooting the solar power system. The solar power system sites must be inspected regularly for damage due to vandalism or wildlife. Loose or damaged wiring can cause severe voltage to drop (power loss) or an open circuit of the array, battery or load. Primarily, the recommended maintenance should be carried out as mentioned in Section 4 as most of the issues can be resolved. Following are some of the scenarios which might contribute to the failure of the system to operate within the design parameters:

- Temperature can affect the performance of the system. The batteries tend to overcharge easier at hot temperature and will not have as much capacity when cold. Also, charging current of the solar panels becomes substantially higher in cold conditions. Therefore, consider the current at cold conditions when sizing the system.
- Smaller solar array or battery bank along with higher usage might result in system batteries being under-charged. Some systems might contain small concealed loads that can slowly draw down the batteries.
- The angle of the panel, shading, high level haze and dust on panel plays a vital role as the solar panel output is highly dependent on it. A panel can become less productive or defective over time if they are not properly connected as required for getting the appropriate output. To detect this, remove the charge controller from the panel and measure the voltage across it. In sunny conditions, the output should be around 36-44V for a 24V system. A smaller value could reflect a problem with the panel. To check the panel's present output, contact a local solar dealer.
- It is important to ensure that the battery bank have correct series-parallel configuration to obtain accurate system voltage and current. Sometimes, the battery goes bad after which a little charging or discharging can result in large changes in system voltage. Also, a battery short somewhere can also lead to reduced battery voltage.
- Problems at the charge controller or panel terminals or fuses and unsoldered crimp connectors in these lines can be caused due to weak or completely disconnected solar panel connections. Also, make sure that the length of the wire used is of appropriate length.
- The charge controller requires to read an accurate battery voltage to regulate the charging correctly. Hence, the voltage drop from the battery needs to be minimized. Also, wire that is too small may cause voltage drop.
- Miswired controller including polarity from the panels or batteries or deviation from the wiring instructions such as connecting bypass using jumpers or connecting the negative terminal of the battery other than the specified location is not recommended.
- Greater loads installation than specified by the system design is NOT recommended. This will efficiency and performance of the system leading to damaging the batteries. It should be verified that the load is within the specified limits to avoid damage.
- If none of the above options are applicable to the prevailing problem, a faulty or failed component must be responsible for the situation which should be isolated or replaced.
- If any of the above fails to correct the problem or if new components are required, contact technical support (refer to Section 1.3) for additional assistance, please have available the system model number and a brief description of the problem.



11126 McCormick Road,
Hunt Valley, MD 21031
800-851-4965
sales@ventev.com

ventevinfra.com

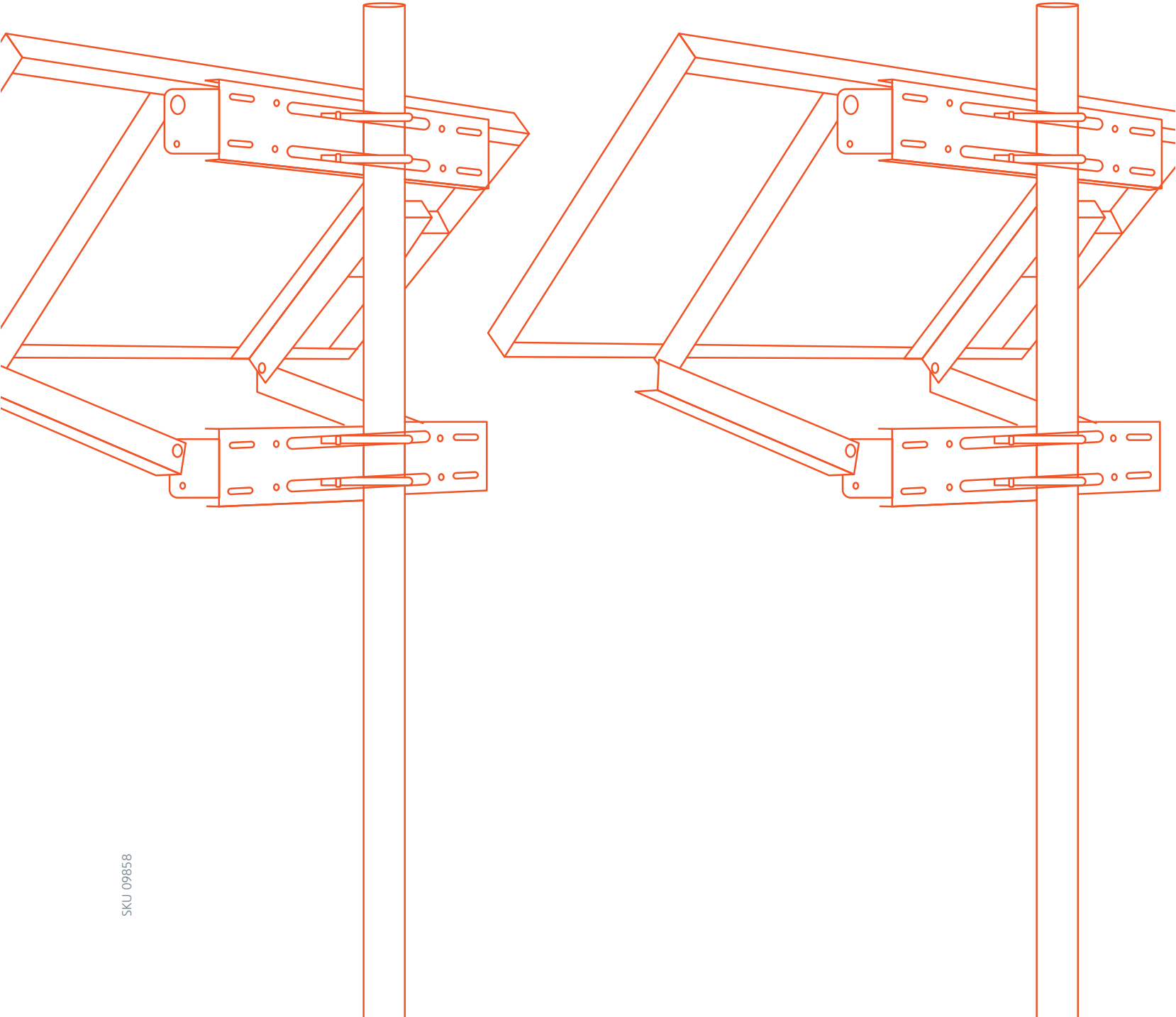

SKU 09858